

FUJI OILMIST SEPARATOR



For Vacuum Pumps

Oil Recycling / Anti-Pollution



FUJI FILTER

FUJI OILMIST SEPARATOR

CLEAN AIR INCREASES EFFICIENCY

The attachment of the FUJI OILMIST SEPARATOR to the air outlet of a rotary pump used in a vacuum pump or air compressor will help to attain and maintain a desirable working environment. This special filter, developed based on our extensive experience in this area, removes oilmist and contaminants, and also arrests noise. FUJI OILMIST SEPARATOR's advantages over air ducts include: lower costs, work space saving, environmental preservation, and easy maintenance.

FCT TYPE



FDT TYPE

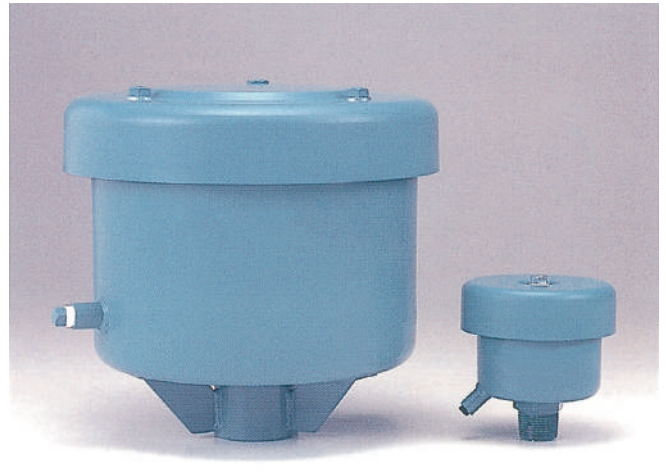

ELEMENT



FEATURES

- Near total removal (99.9%) of oilmist and contaminants in the exhaust of rotary pumps.
- Excellent noise arresting performance.
- Reduced oil consumption as mist is coalesced and returned to the pump.
- Less expensive than exhaust ducts.
- Easy to operate thanks to filter system.
- Easy replacement of elements.
- Easy installation.

The Oilmist Separator can also be used for the removal of oilmist in the exhaust units of various pneumatic equipment or in compressed air for use in chemical plants, as well as in the exhaust units of vacuum pumps.

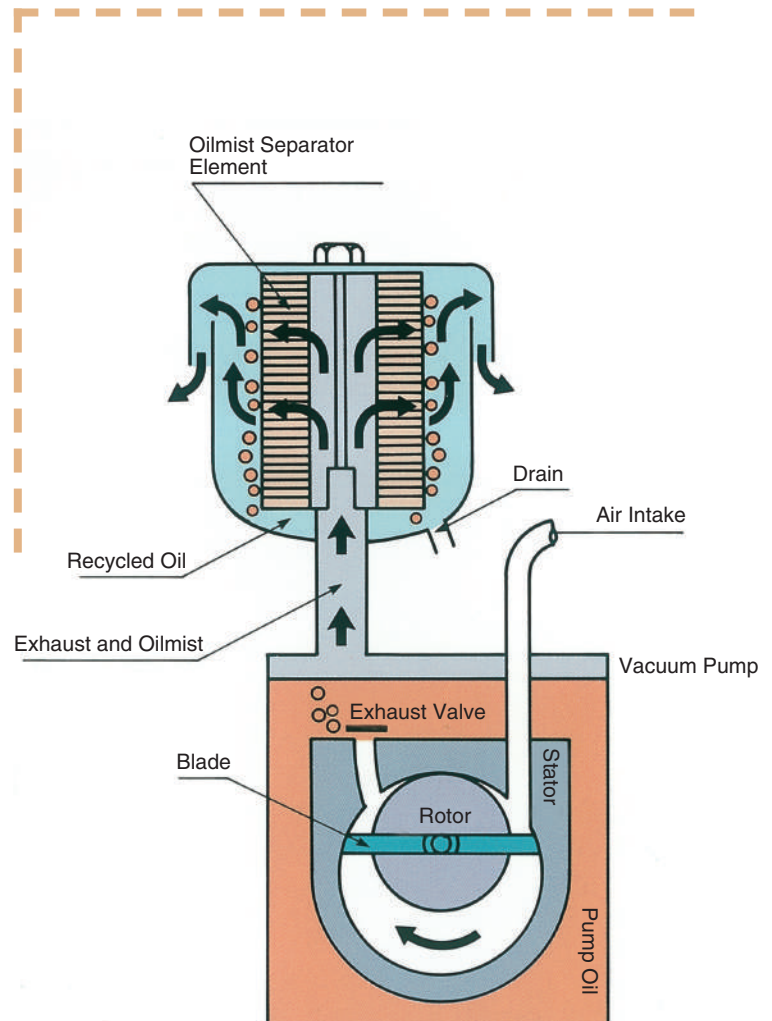

(FCT TYPE (Closed type))
(Applicable for FCT-500 and above)

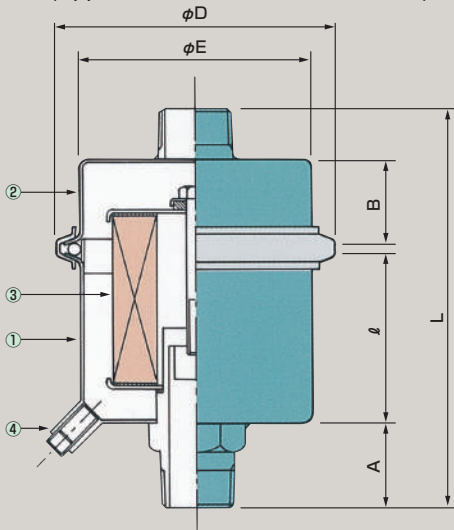

FCT TYPE (Closed type)

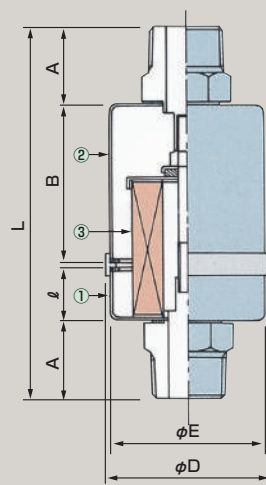

FOT TYPE (Open type)

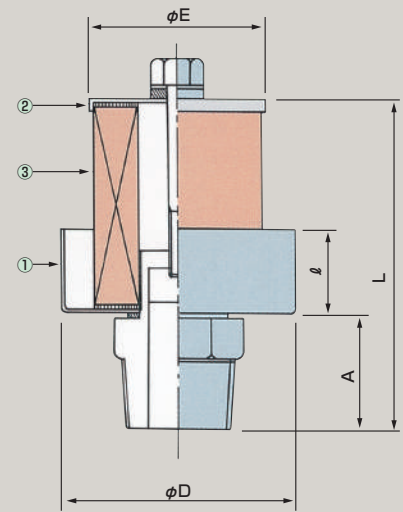

①Body (Material: SPC) ②Upper Cover (Material: SPC) ③Cartridge ④Drain (Material: SPC)

FDT TYPE (Semi-open type)

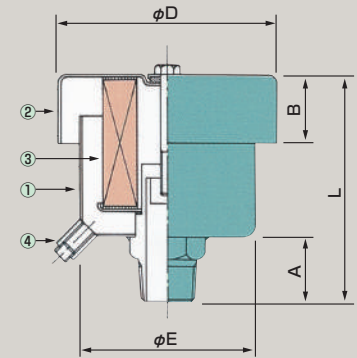

Selection of Oilmist Separators

- Base selection on exhaust volume of vacuum pump and flow rate shown in specifications chart.
- Initial pressure loss is set at under 0.1 kgf/cm² on all types.
- When an initial pressure loss of under 0.05 kgf/cm² is necessary, please select a unit with a one stage larger flow rate.
- For cartridges, please consult Element No. column in specifications chart.
- For duct piping to outside location, select FCT Type, and connection to the "OUT" side is with a union joint.

We can design larger types of FUJI OILMIST SEPARATORS to meet your specifications.

SPECIFICATIONS

MODEL	Flowrate (ℓ /min)	Connection	Element		Dimensions (mm)					
					φ D	L	A	B	φ E	ℓ
FOT - 50 - 8A	30	R1/4	OMS - 45 - 35	1	47	62.5	21.5	*	47	4.5
FOT - 100 - 15A	50	R1/2	OMS - 45 - 45	1	58	78.5	27.5	*	47	20
FOT - 150 - 20A	80	R3/4	OMS - 45 - 70	1	58	108.5	31.5	*	47	22
FOT - 250 - 25A	100	R1	OMS - 45 - 60	1	70	100	24.5	*	53	25
FDT - 250 - 25A	100	R1	OMS - 50 - 60	1	90	95	34	20	70	61
FDT - 500 - 25A	300	R1	OMS - 75 - 75	1	128	133	38	40	102	95
FDT - 1300 - 40A	600	R1 1/2	OMS - 100 - 95	1	150	161	43	40	120	118
FDT - 2000 - 50A	1000	R2	OMS - 100 - 145	1	170	215	47	60	130	168
FDT - 4000 - 50B	2000	Rp 2	OMS - 100 - 95	3	310	277	64	62	270	213
FDT - 6000 - 65B	3000	Rp2 1/2	OMS - 100 - 145	3	310	333	70	82	270	263
FDT - 6500 - 80B	3000	Rp 3	OMS - 100 - 95	5	390	290	75	70	350	215
FDT - 10000 - 100B	6500	Rp 4	OMS - 100 - 145	5	390	353	88	90	350	265
FDT - 13000 - 100B	7500	Rp 4	OMS - 100 - 195	5	390	403	88	110	350	315
FCT - 100 - 15A	50	R1/2	OMS - 45 - 45	1	60	137	27	59	58	21
FCT - 150 - 20A	80	R3/4	OMS - 45 - 70	1	60	173	32	86	58	21
FCT - 250 - 25A	100	R1	OMS - 50 - 60	1	74	164	35	71	70	24
FCT - 500 - 25A	300	R1	OMS - 75 - 75	1	126	179	38	38	105	76
FCT - 1300 - 40A	600	R1 1/2	OMS - 100 - 95	1	150	212	43	47	130	95
FCT - 2000 - 50A	1000	R2	OMS - 100 - 145	1	150	295	47	69	130	139
FCT - 3000 - 50A	1500	R2	OMS - 100 - 195	1	164	329	47	81	143	161
FCT - 4000 - 50B	2000	Rp 2	OMS - 100 - 95	3	290	320	64	75	270	147
FCT - 6000 - 65B	3000	Rp2 1/2	OMS - 100 - 145	3	290	407	70	95	270	205
FCT - 6500 - 80B	3000	Rp 3	OMS - 100 - 95	5	370	336	75	75	350	147
FCT - 8000 - 80B	4000	Rp 3	OMS - 100 - 195	3	290	466	75	115	270	237
FCT - 10000 - 50B	6500	Rp 2	OMS - 100 - 145	5	370	408	64	95	350	215
FCT - 10000 - 100B	6500	Rp 4	OMS - 100 - 145	5	370	435	88	87	350	215
FCT - 13000 - 100B	7500	Rp 4	OMS - 100 - 195	5	370	477	88	107	350	237

*When used at a constant vacuum level or for continuous service under low vacuum conditions, please consult us.

Fire Preventive/Corrosion Resistant Ceramic Elements

The oilmist intake comprises a special environment including organic solvents and high concentration oxygen, and so measures to prevent fire and corrosion are necessary. These CRM-100 Series Fire Preventive/Corrosion Resistant Ceramic Elements were developed for this purpose, and they are applicable for the FCT-1300 model and above. Dimensionally speaking, they are compatible with the OMS-100-95, OMS-100-145 and OMS-100-195. If you are considering fitting the CRM-100 Series Elements in your current FCT vessel, please consult our sales department for advice on the feasibility of this.

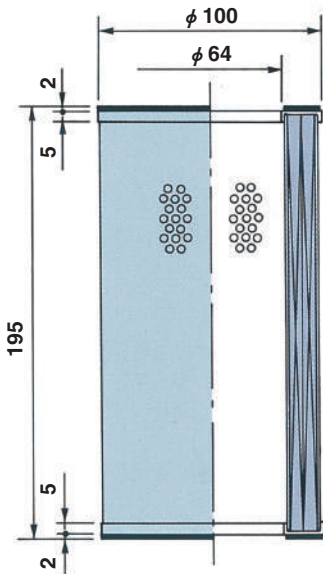

CRM-100-195

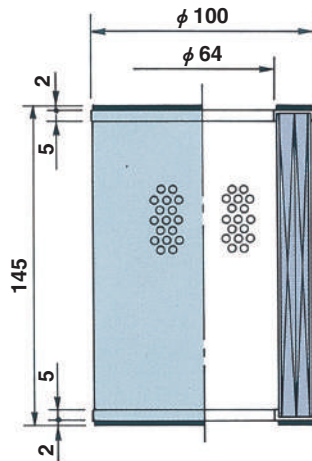

CRM-100-145

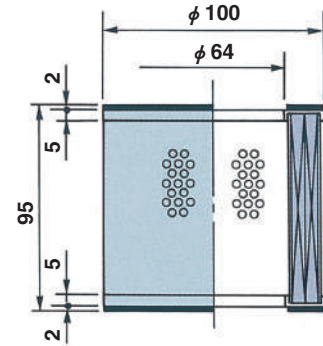

CRM-100-95



FUJI FILTER 富士フィルター工業株式会社
MFG.CO.,LTD.
2-3-4 Nihonbashi, Chuo-ku, 103-8308 Tokyo JAPAN
TEL: +81-3-3241-4201 FAX: +81-3246-1288 www.fujifilter.com